



DOREX 2000 AND 2000H

front access carbon filters

Features:

- High single-pass efficiency
- 500 ft/min design velocity
- 25" W.G. resistance at 500 fpm
- Removable trays
- Standard trays are cold-rolled steel with black baked enamel finish
- Available in half size
- Units bolt together to form banks of any capacity
- Stainless steel trays or epoxy coated trays are available as an option

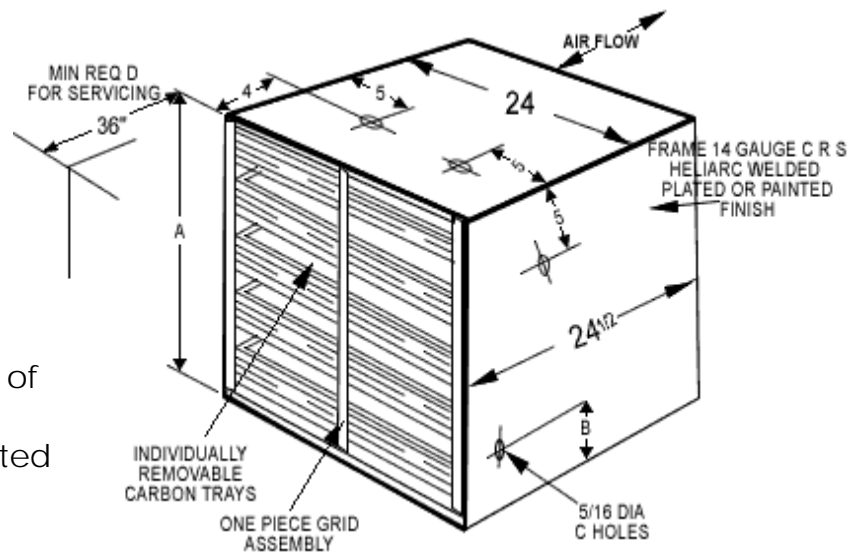

Specifications:

The 2000 and 2000H front access housing are unique in design and versatility. A one piece removable grid is used for easy access to the trays.

Unit Designation	A	B	C	D	Rated Flow at .25 W.G.	Lbs. of Carbon (Approximate)
2000	10	5	8	20	2000 C.F.M.	90
2000-H	5	-	6	10	1000 C.F.M.	45